

GEZE

GB

INSTALLATION AND USE INSTRUCTIONS

CHAIN ACTUATOR

ΣOL N

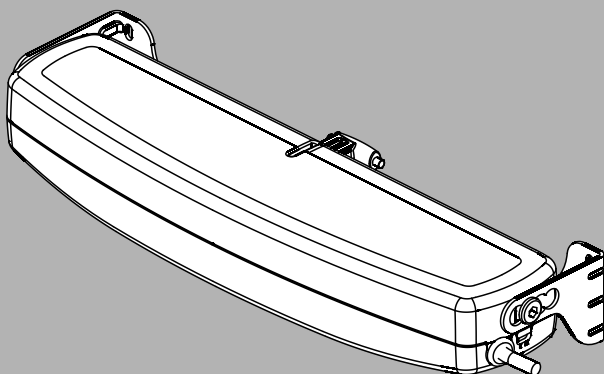

PATENTED



Ident.-Nr. 129043

45146-9-0951_01

**BEFORE INSTALLING AND USING THE ACTUATOR, IT IS
COMPULSORY FOR THE INSTALLER AND THE USER TO READ
AND UNDERSTAND THIS MANUAL IN ALL ITS PARTS.**

**THIS MANUAL IS AN INTEGRAL PART OF THE ACTUATOR
AND MUST BE PRESERVED FOR FUTURE REFERENCE
UNTIL DEMOLITION OF THE SAME.**

1- DECLARATION OF "CE" CONFORMITY

ΣΟΛ Ν

2

INSTALLATION AND USE INSTRUCTIONS

1- DECLARATION OF "CE" CONFORMITY	
.....	page 04
2- GENERAL REMARKS	
2.1- General instructions.....	page 05
2.2- Installer and user.....	page 05
2.3- Warranty.....	page 05
2.4- Technical assistance.....	page 05
2.5- Reserved rights.....	page 05
2.6- Description of personnel.....	page 06
3- TECHNICAL DESCRIPTION	
3.1- Rating plate and "CE" marking.....	page 07
3.2- Components and dimensions.....	page 08
3.3- Technical data.....	page 09
3.4- Formulas for the calculation of thrust force or tractive force.....	page 10
3.5- Purpose.....	page 10
3.6- Limitations of use.....	page 11
3.7- Package.....	page 11
4- SAFETY	
4.1- General instructions.....	page 13
4.2- Safety Devices.....	page 13
4.2.1- Protection against electric hazard.....	page 13
4.3- Safety plates.....	page 13
4.4- Residual risks.....	page 14
5- INSTALLATION	
5.1- General instructions.....	page 15
5.2- Top hung windows.....	page 18
5.3- Bottom hung windows.....	page 19
5.4- Electrical Connections.....	page 20
5.5- Control devices.....	page 21
5.6- Adjustment of the window frame closing.....	page 22
5.7- Emergency procedures.....	page 23
6- USE AND OPERATION	
6.1- Use of the actuator.....	page 24
7- MAINTENANCE	
7.1- General instructions.....	page 25
8- DEMOLITION	
8.1- General instructions.....	page 26
9- SPARE PARTS AND ACCESSORIES UPON REQUEST	
9.1- General instructions.....	page 26
FIGURES	
.....	page 28



Herstellereklärung

(Declaration of manufacturer, Déclaration de fabricant)

nach Anhang II B der Maschinenrichtlinie 89/392/EWG in der Fassung 98/37/EG
in accordance with annex II B of the Machines Directive 89/392/EWG in the version 98/37/EG
en conformité avec la directive UE 89/392/EWG en version 98/37/EG

Hersteller: GEZE GmbH
(Manufacturer, Fabricant) Reinhold-Vöster-Str. 21 – 29
D-71229 Leonberg

Produktbezeichnung: GEZE Kettenantrieb ΣOL N, 230 V AC, 24 V DC
(Product identifier, Désignation du produit)

Erklärung (Declaration, Déclaration):

Der Antrieb ist entwickelt, konstruiert und gefertigt in Übereinstimmung mit der Maschinenrichtlinie 89/392/EWG in der Fassung 98/37/EG und der Bauproduktenrichtlinie 89/106/EWG in der Fassung 93/68/EG in alleiniger Verantwortung der GEZE GmbH und ist nicht selbständig verwendungsfähig.

The electrical actuator has been developed, designed and manufactured in accordance with the Machines Directive 89/392/EWG in the version 98/37/EG and the Construction Products Directive 89/106/EWG in the version 93/68/EG, under the sole responsibility of GEZE GmbH and is not independently useable.

Le mécanisme est développé et fabriqué en conformité avec la directive UE 89/392/EWG en version 98/37/EG et la directive pour la fabrication de produits de construction 89/106/EWG en version 93/68/EG en seule responsabilité de la société GEZE et n'est pas utilisable indépendamment.

Mitgeltende EU-Richtlinien (Concurrent EU Directives, Directives UE):

- EMV-Richtlinie 89/336/EWG in der Fassung 93/31/EWG
- Niederspannungsrichtlinie 2006/95/EG

Angewandte harmonisierte Normen (Applied harmonised standards, normes harmonisées appliquées):

- EN 60335-1
- EN 61000-3-2
- EN 61000-3-3
- EN 55014-1
- EN 55014-2

Angewandte nationale Normen und technische Spezifikationen

(Applied national standards and technical specification, normes nationales appliquées et spécification technique):

- BGR 232

Dokumentation (Documentation, Documentation):

Die Lieferdokumentation, die Herstellereklärung und die Betriebsanleitung sind dem Antrieb beiliegend.
The consignment documentation, the declaration of manufacturer and the operating instruction are included with the control unit.

La documentation de livraison, la déclaration du fabricant ainsi que le manuel d'utilisation sont conjoint au mécanisme.

Hinweis (Note, Notes):

Die Inbetriebnahme des beschriebenen Antriebes ist solange untersagt, bis festgestellt wurde, dass die Fensteranlage in die dieser Antrieb eingebaut werden soll, den Bestimmungen der Maschinenrichtlinie und der Bauproduktenrichtlinie entspricht.

The initiation starting of the electrical actuator is not allowed, until it where determined that the window systems in which the electrical actuator is integrated, are in accordance with the Machines Directive and the Construction Products Directive.

Pour pouvoir effectuer la mise en service du mécanisme il est obligatoire de constater que la fenêtre dans la quelle le mécanisme doit être installé est conforme à la directive de machines ainsi qu'à la directive concernant les produits de la construction.

Hermann Alber
Geschäftsführer

Leonberg, den 14. Mai 2008

GEZE GmbH · Reinhold-Vöster-Str. 21-29 · D-71229 Leonberg

Zeichn.-Nr.: 45146-B-0957

Mat.-Nr.: 129 050
And.-St. 00

04-250/0958/11760

2.1- GENERAL INSTRUCTIONS

BEFORE INSTALLING AND USING THE ACTUATOR, IT IS COMPULSORY THAT THE INSTALLER AND THE USER CAREFULLY READ AND UNDERSTAND THIS MANUAL IN ALL ITS PARTS.



THIS MANUAL IS AN INTEGRAL PART OF THE ACTUATOR AND MUST BE PRESERVED FOR FUTURE REFERENCE.



THE MANUFACTURER HAS NO LIABILITY FOR ANY EVENTUAL DAMAGE TO PERSONS, ANIMALS AND THINGS DUE TO THE INOBSERVANCE OF THE DIRECTIONS DESCRIBED IN THIS MANUAL.

2.2- INSTALLER AND USER

THE ACTUATOR INSTALLATION CAN BE PERFORMED EXCLUSIVELY BY COMPETENT AND QUALIFIED TECHNICAL PERSONNEL SATISFYING THE PROFESSIONAL AND TECHNICAL REQUIREMENTS FORESEEN BY THE LAWS IN FORCE IN THE COUNTRY OF INSTALLATION.



THE ACTUATOR CAN BE USED EXCLUSIVELY BY A USER ACTING IN COMPLIANCE WITH THE INSTRUCTIONS CONTAINED IN THIS MANUAL AND/OR IN THE MANUAL OF THE ACTUATOR CONTROL DEVICE (e.g.: CONTROL UNIT).

2.3- WARRANTY

THE ACTUATOR WARRANTY EXPIRES, IF ITS USE DOES NOT COMPLY WITH THE INSTRUCTIONS AND DIRECTIONS DESCRIBED IN THIS MANUAL, AS WELL AS IF NON-ORIGINAL COMPONENTS, ACCESSORIES, SPARE PARTS, AND CONTROL SYSTEMS ARE USED.

2.4- TECHNICAL ASSISTANCE

For the technical assistance apply to your Dealer or to the Manufacturer.

2.5- RESERVED RIGHTS

The reserved rights on this manual "Installation and use instructions" remain the property of the Manufacturer.

Each information herein contained (text, drawings, diagrams, etc.) is reserved.

No part of this manual can be reproduced and disclosed (totally or partially) by any reproduction means (photocopies, microfilms or other) without written authorization of the Manufacturer.

2.6- DESCRIPTION OF PERSONNEL

USERS MUST NEVER PERFORM OPERATIONS RESERVED FOR MAINTENANCE PEOPLE OR SPECIALISED TECHNICIANS. THE MANUFACTURER DECLINES ALL LIABILITY FOR DAMAGE DERIVING FROM FAILURE TO OBSERVE THE ABOVE REQUIREMENTS.

Specialised electrician:

A specialised electrician must be able to install the actuator, start it and operate it both in normal conditions and in the maintenance mode; he/she is qualified to perform all electrical and mechanical adjustment and maintenance operations. He/she is allowed to work on live electrical cabinets and junction boxes.

User:

A specialised person capable of operating the actuator under normal conditions by using the relative controls. He/she must also be able to operate with the actuator under “maintenance” in order to perform simple routine maintenance operations (cleaning), and start or reset the actuator following an unscheduled stop.

3.1- RATING PLATE AND "CE" MARKING

The "CE" marking certifies the compliance of the machine with the essential safety and health requirements foreseen by the product European Directives.

The rating plate is an adhesive plate in polyester, silk-screen printed in black, having the following size: L= 36 mm - H= 50 mm.

It is applied externally on the actuator. The plate (**Fig. 1**) bears in readable and indelible way the following data:

- logo and address of the manufacturer
- type and model
- voltage and intensity of power supply (V - A)
- type of service S_2 (min)
- absorbed electric power P (W)
- thrust and tractive force F (N)
- idle translation speed (mm/s)
- protection degree (IP)
- symbol of double insulation (only for mod. C20/230V)
- "CE" marking
- serial number
- month/year of production

Fig. 1

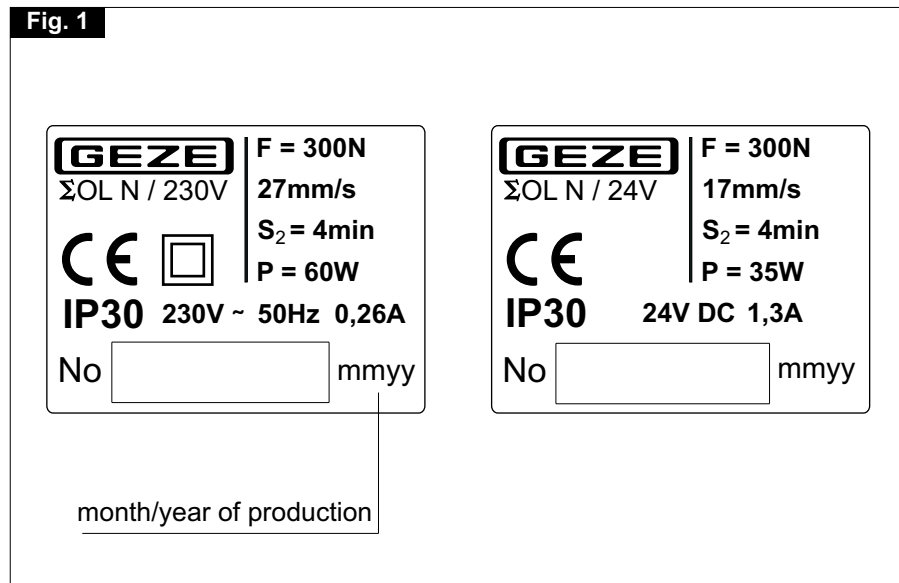

3.2- COMPONENTS AND DIMENSIONS

Fig. 2 Dimensions in mm

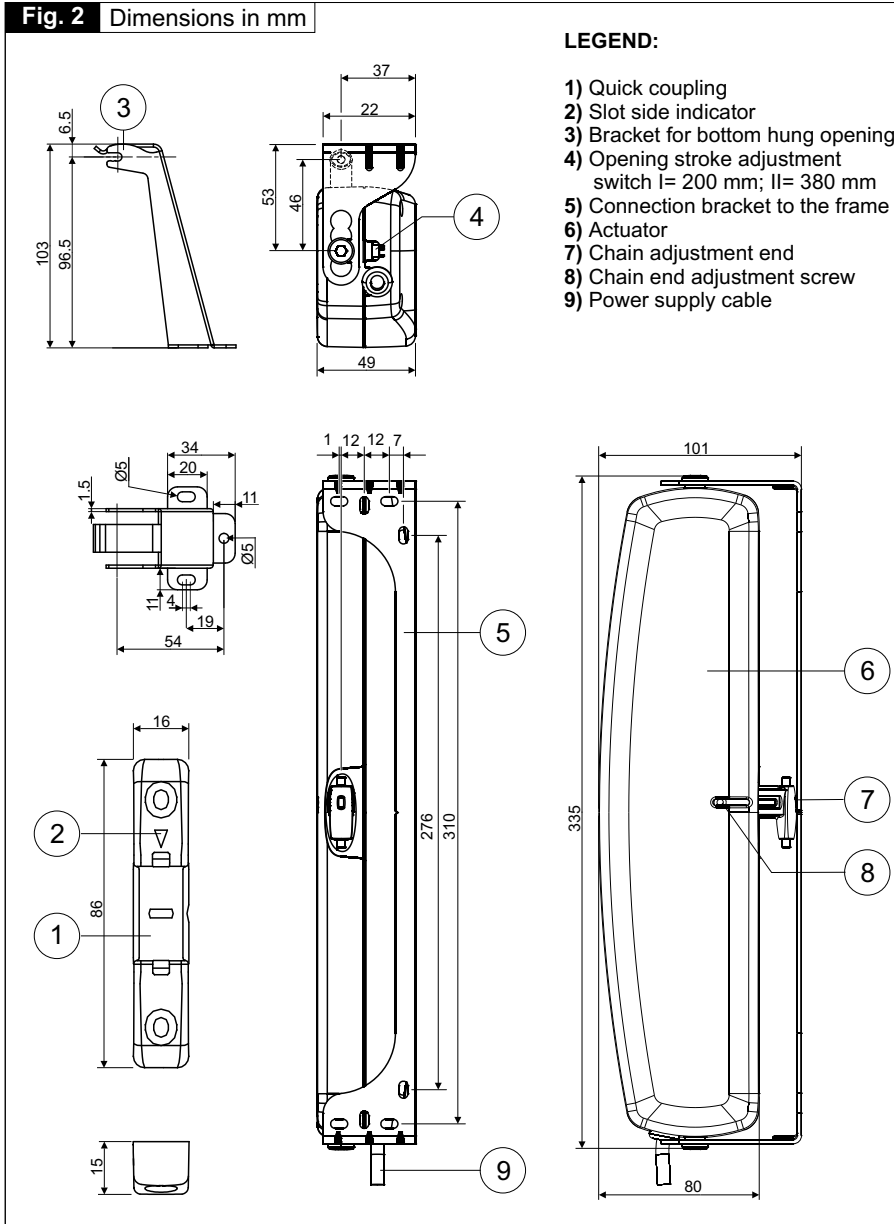

3.3- TECHNICAL DATA

Tab. 1 contains the technical data characterising the actuators.

	C30/230V		C30/24V			
Power supply voltage	230 V 50 Hz		24 V==			
Absorbed current	0,26 A		1,3 A			
Absorbed power with load	60 W		35 W			
Maximum applicable thrust load	300 N					
Maximum applicable tractive load	300 N					
Idle translation speed	27 mm/s		17 mm/s			
Duration of maximum idle stroke	14 s		22 s			
End of stroke selected at mm			200	380		
Minimum height H (mm) of the window frame	Position assembly brackets ⁽¹⁾	0	Top hung	250	400	
			Bottom hung	500	1000	
		1	Top hung	250	400	
			2	Top hung	350	500
				3	Bottom hung	500
Minimum window frame height ⁽²⁾	H= 500 + 950 mm					
End of stroke selectable at ⁽³⁾	200 + 380 mm					
Protection against electric shocks	Class II		Class III			
Type of service S ₂ ⁽⁴⁾	4 min					
Operating temperature	-5°C +50°C					
Protection degree of electric devices	IP 30					
Adjustment of the window frame connection	0+22,5 mm (Top hung) 0+30 mm (Bottom hung)					
Parallel electric connection of more actuators on the same window	Only with proper electronic device					
Parallel electric connection of more actuators on different windows	Yes (see wiring diagram)					
Actuator weight with brackets	1,1 kg					
Gross weight	1,5 kg					
Electronics with warning horn to signal to the user the wrong assembling ⁽⁵⁾						
⁽¹⁾ For the assembly position of the brackets see FIG. 7 ⁽²⁾ Distance of the actuator from the window opening hinge valid only with max. stroke 380 mm ⁽³⁾ Tolerance on the tripping precision of the limit switch at output: +/- 10 mm ⁽⁴⁾ Service of limited duration according to EN 60034 ⁽⁵⁾ The "buzzer" device enables automatically itself emitting a continuous "beep" as long as the actuator is supplied. For further details on the operation see par. 5.6						

Tab. 1

3.4- FORMULAS FOR THE CALCULATION OF THRUST AND TRACTIVE FORCE

Fig. 3

Horizontal domes or skylights

F = Force necessary for opening or closing
 P = Weight of the skylight or dome (only movable part)

$$F = 0,54 \times P$$

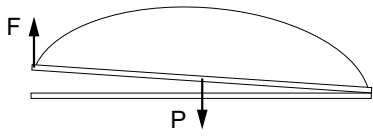
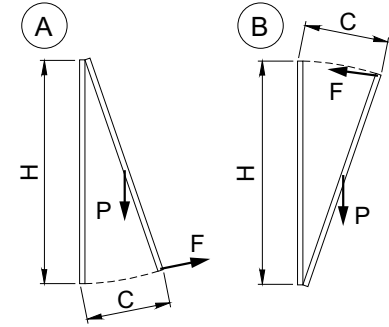

Fig. 4

Top hung windows (A) or bottom hung windows (B)

F = Force necessary for opening or closing
 P = Weight of the window (only movable part)
 C = Window opening stroke
 H = Window height (only movable part)

$$F = (0,54 \times P) \times \left(\frac{C}{H} \right)$$



3.5- PURPOSE



THE ACTUATOR HAS BEEN DESIGNED AND MANUFACTURED TO PERFORM AUTOMATICALLY, BY MEANS OF A CONTROL DEVICE, THE OPENING AND CLOSING OF TOP HUNG WINDOWS, BOTTOM HUNG WINDOWS, PIVOT WINDOWS, AND SKYLIGHTS.

3.6- LIMITATIONS OF USE

The actuator has been designed and manufactured exclusively for the purpose given in **par. 3.5**, therefore, any other type of use is strictly forbidden in order to ensure the safety of the installer and of the user, as well as the efficiency of the actuator itself.



IT IS STRICTLY FORBIDDEN TO USE THE ACTUATOR FOR IMPROPER USES OTHER THAN THE ONE FORESEEN BY THE MANUFACTURER (SEE PAR. 3.5).



IT IS STRICTLY FORBIDDEN TO INSTALL THE ACTUATOR ON THE EXTERNAL SIDE OF THE WINDOW FRAME SUBJECT TO ATMOSPHERIC AGENTS (RAIN, SNOW, ETC.).



THE USE OF THE ACTUATOR IN ENVIRONMENTS WITH POTENTIALLY EXPLOSIVE ATMOSPHERE IS STRICTLY FORBIDDEN.



IT IS COMPULSORY TO KEEP THE PACKAGE AND THE ACTUATOR OUT OF REACH OF CHILDREN.

3.7- STANDARD PACKAGE

Each standard package of the product (cardboard box) contains (**Fig. 5**):

- No.1 Actuator equipped with power supply cable;
- No.1 Window frame connection bracket (**Ref. A**);
- No.1 Bracket for bottom hung opening (**Ref. B**);
- No.1 Small parts package (quick coupling, No.2 bracket fastening lateral screws, No.7 screws AF Ø 4.2 x 19 mm for fastening the bracket to the window frame (**Ref. C**);
- No.1 (2 mm) Allen wrench (**Ref. D**);
- No.1 Installation and use instructions (**Ref. E**).



MAKE SURE THAT THE ABOVE DESCRIBED COMPONENTS ARE CONTAINED IN THE PACKAGE, AS WELL AS THAT THE ACTUATOR HAS NOT BEEN DAMAGED DURING TRANSPORT.



SHOULD ANY ANOMALY BE DETECTED, IT IS FORBIDDEN TO INSTALL THE ACTUATOR, AND IT IS COMPULSORY TO REQUIRE TECHNICAL ASSISTANCE FROM YOUR DEALER OR THE MANUFACTURER.



THE PACKAGING (PAPER, PLASTIC, ETC.) HAS TO BE DISPOSED ACCORDING TO THE LAWS IN FORCE.

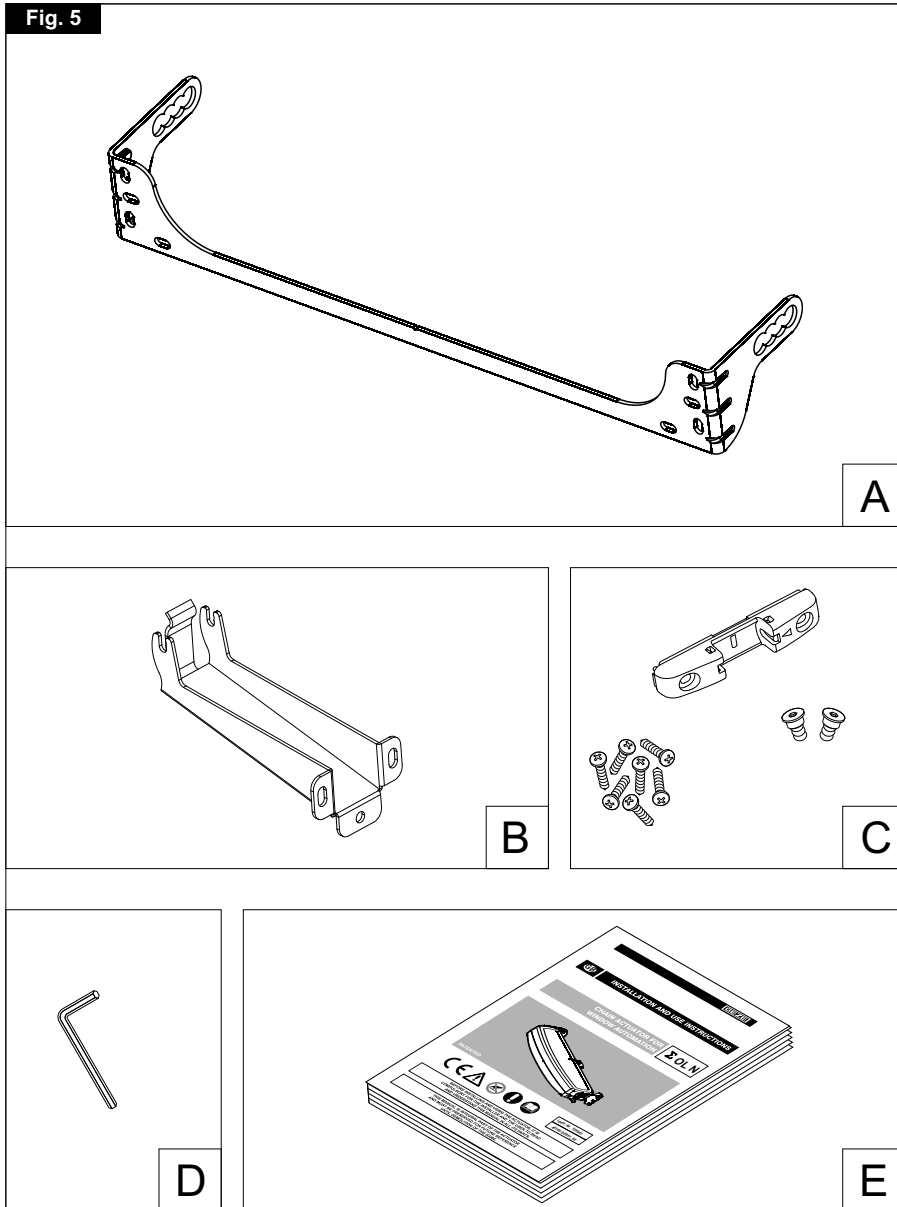

4.1- GENERAL INSTRUCTIONS



OPERATORS MUST BE INFORMED OF ACCIDENT RISKS, SAFETY DEVICES AND THE GENERAL ACCIDENT PREVENTION REGULATIONS ESTABLISHED BY INTERNATIONAL DIRECTIVES AND BY THE LAW IN FORCE IN THE COUNTRY OF USE. ALL OPERATORS MUST STRICTLY COMPLY WITH THE ACCIDENT PREVENTION REGULATIONS IN FORCE IN THE COUNTRY OF USE.



DO NOT REMOVE OR ALTER THE PLATES PLACED ON THE ACTUATOR BY THE MANUFACTURER.



IF THE WINDOW FRAME IS ACCESSIBLE FROM OR INSTALLED AT A HEIGHT OF LESS THAN 2.5 m FROM THE GROUND, AND IF IT CAN BE CONTROLLED BY AN UNTRAINED USER OR WITH A REMOTE CONTROL DEVICE, FIT AN EMERGENCY STOP SYSTEM WHICH AUTOMATICALLY CUTS IN TO PREVENT THE RISK OF CRUSHING OR DRAGGING PARTS OF THE BODY INSERTED BETWEEN THE MOVING AND FIXED PARTS OF THE WINDOW FRAME.

4.2- SAFETY DEVICES

4.2.1- PROTECTION AGAINST ELECTRIC HAZARD

The actuator is protected against electric hazard due to direct and indirect contacts.

The protection measures against direct contacts aim at protecting people against hazards due to contact with active parts, usually live parts; while the protection measures against indirect contacts aim at protecting people against hazards due to conducting part, which are usually insulated, but could become live in case of failure (insulation failure).

The adopted protection measures are the following:

- 1) Insulation of live parts by means of a plastic material body;
- 2) Enclosure with suitable protection degree;
- 3) **Only for the mod. 230V provided with protection against electric shocks:**
Protection of passive type given by the use of components with double insulation, also called components of class II or with equivalent insulation.

4.3- SAFETY PLATES



IT IS FORBIDDEN TO REMOVE, MOVE, SPOIL OR IN ANYWAY REDUCE THE VISIBILITY OF THE SAFETY PLATES. FAILURE TO OBSERVE THE ABOVE MAY CAUSE SERIOUS HARM TO PEOPLE AND DAMAGE TO PROPERTY. THE MANUFACTURER DECLINES ALL LIABILITY FOR ANY DAMAGE CAUSED BY THE FAILURE TO OBSERVE THE ABOVE REQUIREMENT.

Fig. 6 illustrates the safety plate: this must be applied directly to the outside of the actuator or near it and always in a position where it can be seen by the installer and/or operator.

4.4- RESIDUAL RISKS

The actuator does not have residual risks. The installer and the user are herewith informed that after the actuator has been installed on the window, the actuator drive can accidentally generate the following residual risk:

Residual risk:

Hazard of squashing or dragging of body parts inserted between the movable and the fix part of the window frame.

Exposure frequency:

Accidental and when the installer or the user decides to perform a wrong voluntary action.

Severity of the damage:

Light lesions (usually reversible).

Adopted measures:

Before enabling the device, it is compulsory to verify that near the window there are not persons, animals or things whose safety may be accidentally jeopardized. During actuator operation, it is compulsory to be in a safe control position assuring visual control on the window movement.

Fig. 6



5.1- GENERAL INSTRUCTIONS

THE ACTUATOR INSTALLATION CAN BE PERFORMED EXCLUSIVELY BY COMPETENT AND QUALIFIED TECHNICAL PERSONNEL SATISFYING THE PROFESSIONAL AND TECHNICAL REQUIREMENTS FORESEEN BY THE LAWS IN FORCE IN THE COUNTRY OF INSTALLATION.



THE ACTUATOR PERFORMANCE MUST BE SUFFICIENT TO ENSURE THE CORRECT MOVEMENT OF THE WINDOW. IT IS COMPULSORY TO VERIFY THE THRUST OR TRACTIVE FORCE ACCORDING TO THE TYPE AND WEIGHT OF THE WINDOW (PAR. 3.4). IT IS FORBIDDEN TO EXCEED THE LIMITS GIVEN IN TAB. 1 CONCERNING THE TECHNICAL DATA (PAR. 3.3).



THE ACTUATOR INSTALLATION MUST BE PERFORMED EXCLUSIVELY WITH CLOSED WINDOW OR SKYLIGHT.



BEFORE PERFORMING THE INSTALLATION OF THE ACTUATOR ON HOPPER WINDOWS, VERIFY THAT ON BOTH SIDES OF THE WINDOW TWO COMPASS STROKE LIMIT DEVICES ARE INSTALLED IN ORDER TO AVOID THE ACCIDENTAL FALL OF THE WINDOW.



FOR CORRECT OPERATION OF THE ACTUATOR, THE WINDOW FRAME MUST HAVE A MINIMUM HEIGHT (DISTANCE OF THE ACTUATOR FROM THE WINDOW OPENING HINGE) EQUAL TO THE VALUES QUOTED IN TAB. 1.



VERIFY THAT THE POSITIONS OF THE LABELS LOCATED ON THE QUICK COUPLING CORRESPOND TO THE LABELS ON THE ACTUATOR: RED LABEL WITH LETTER "A" FOR THE TOP HUNG ASSEMBLY, GREEN LABEL WITH LETTER "B" FOR VERTICAL ASSEMBLY.



VERIFY THAT THE DISTANCE "D" BETWEEN THE WINDOW FRAME (ON WHICH THE FIXING OF THE ACTUATOR IS FORESEEN) AND THE WINDOW FRAME WING (ON WHICH THE BRACKET FIXING IS FORESEEN) IS INCLUDED WITHIN 0 mm AND 30 mm, FOR THE TOP HUNG ASSEMBLY (SEE FIG. 7a), AND WITHIN 0 mm AND 22,5 mm FOR THE BOTTOM HUNG ASSEMBLY (SEE FIG. 7b).



THE FITTING SURFACE FOR THE ARS RAPID COUPLING DEVICE MUST BE PERFECTLY FLAT AND/OR SMOOTH.

Fig. 7a Dimensions in mm

THE POSITIONS 1 - 2 - 3 - 0 ARE TO BE USED ACCORDING TO THE OVERLAPPED PART **D** OF THE WINDOW

OVERLAPPED PART D	ACTUATOR POSITION	TYPE OF APPLICATION
0 ÷ 15 mm	0	TOP HUNG
15 ÷ 22,5 mm	1	
22,5 ÷ 30 mm	2	



THE FASTENING POSITION **A** HAS TO BE VERIFIED AND EVALUATED ACCORDING TO THE PROFILE/LENGTH OF THE WING/FRAME AND OF THE WINDOW LIGHT.



FOR WINDOWS HAVING A "WINDOW LIGHT" LOWER THAN 500 mm, IT IS SUGGESTED TO ADJUST THE STROKE 200 mm (SWITCH POS.I).

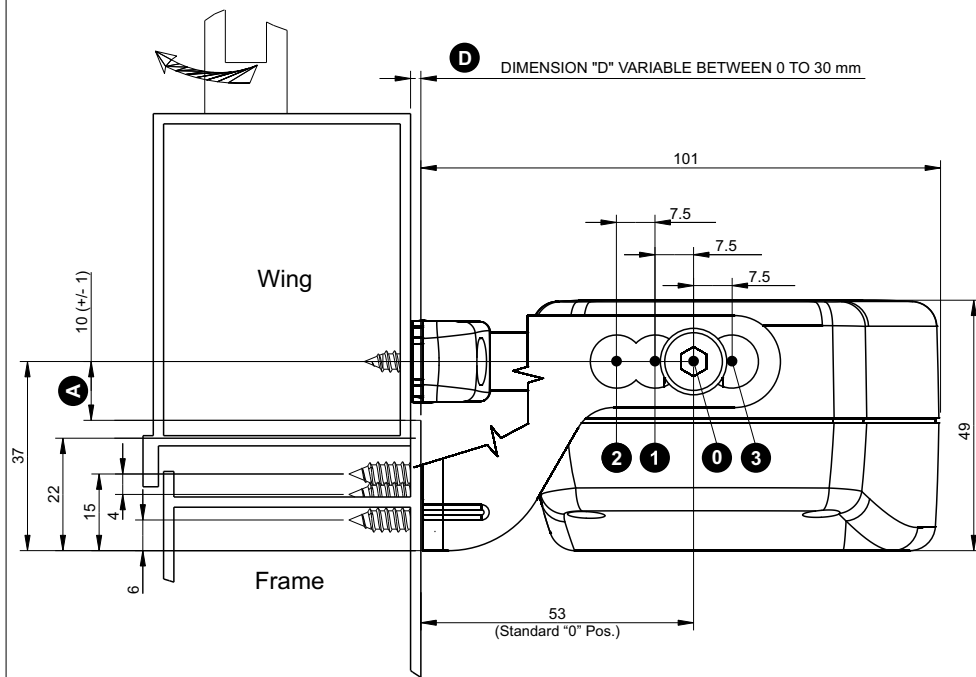

Fig. 7b Dimensions in mm

THE POSITIONS 1 - 2 - 3 - 0 ARE TO BE USED ACCORDING TO THE OVERLAPPED PART **D** OF THE WINDOW

0 ÷ 15 mm	0	BOTTOM HUNG (see Fig.34)
7,5 ÷ 22,5 mm	3	BOTTOM HUNG (see Fig.34)



THE DIMENSION **C** IS INCLUDED BETWEEN 96,6 mm AND 119,1 mm.



THE FASTENING POSITION **A** HAS TO BE VERIFIED AND EVALUATED ACCORDING TO THE PROFILE/LENGTH OF THE WING/FRAME AND OF THE WINDOW LIGHT.

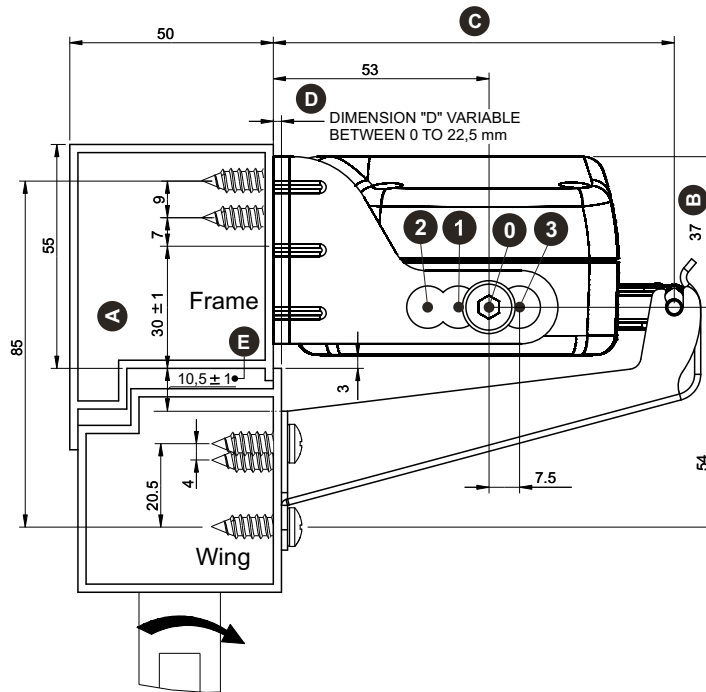

STROKE	MIN. WINDOW LIGHT	OPENING ANGLE	MOTOR OVERALL DIMENSIONS (B)
200 mm	500 mm	22°	39.5 mm
380 mm	900 mm	24.5°	41.5 mm

5.2- TOP HUNG WINDOWS (Fig. 8 and Fig. 14 - 25)

- 1) Open the package (par. 3.7) and extract the various components;
- 2) Fig. 14- With a pencil draw the centre line "X" of the window frame;
- 3) Fig. 15- Align the quick coupling to the centre line using as reference the rib (Ref. 1) located in the centre of the same with the quick release side indicator on the right (Ref. 2);
- 4) Fig. 16- Position the quick coupling at a minimum height of 10 mm from the frame and mark the drilling points;
- 5) Fig. 17/18- With a suitable drill, bore two holes of \varnothing 3.7 mm on the wing and tighten the quick coupling with proper screws;
- 6) Fig. 19- Align to the centre line the window frame connection bracket using as reference the indicator of the centre line (Ref. 1) located in the middle of the same;
- 7) Position the bracket on the frame at such a height as to align the axis of the bracket fastening seat with the axis of the fastening holes of the quick coupling, as indicated in Fig. 20 and mark the drilling points;
- 8) Fig. 21/22- With a suitable drill, bore four holes of \varnothing 3.7 mm on the frame and tighten the bracket with proper screws;

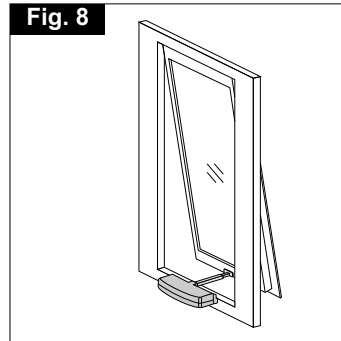

VERIFY THAT THE CHAIN ADJUSTMENT END (FIG. 9 - Ref. A) IS ON THE SAME AXIS OF THE QUICK COUPLING (FIG. 9 - Ref. B). OTHERWISE, REPEAT THE OPERATIONS AND POSITION CORRECTLY; WHEN THEY ARE NOT COAXIAL, THIS MAY DAMAGE THE ACTUATOR AND THE WINDOW FRAME (FIG. 9).

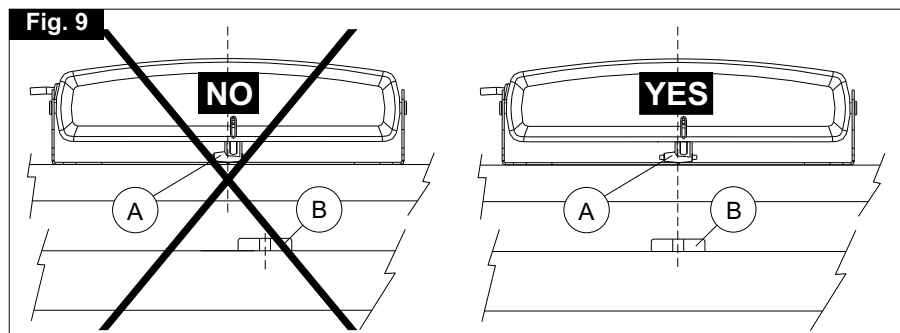

- 9) **Fig. 23-** Loosen the chain end adjustment screw (**Ref. 3**) and connect the actuator to the semi-automatic coupling inserting the chain adjustment end first of all in the left connection point (**Ref. 1**) and then in the right connection point (**Ref. 2**);
- 10) **Fig. 24-** Using the two supplied screws (**Ref. 1**) tighten the actuator to the window frame connection bracket in the most suitable position according to the value of the overlapped part "D" (**see Fig. 7a**) and tighten the chain end adjustment screw (**Fig. 23 - Ref. 3**);
- 11) **Fig. 25-** Adjust the opening stroke by means of the switch (**Ref. 1**) located in the right side of the actuator according to the wing opening;



TO CHANGE THE PRE-SET STROKE, USE A SCREWDRIVER (FIG. 25) WITH SUITABLE TIP. MAKE SURE TO INSERT THE TIP UP TO THE MICROSWITCH BASE AND TO SHIFT IT COMPLETELY. AN INCORRECT IN-BETWEEN POSITION STALLS THE ACTUATOR.

- 12) Perform the electric connection according to the provisions of **par. 5.4** and referring to the wiring diagram.



THE SELECTION OF THE STROKE MUST BE PERFORMED WITH SWITCHED OFF ACTUATOR EXCLUSIVELY BY COMPETENT AND QUALIFIED TECHNICAL PERSONNEL.



CAUTION: VERIFY THAT THE SELECTED STROKE IS SOME CENTIMETRES LOWER THAN THE STROKE EFFECTIVELY ALLOWED BY MECHANICAL LOCKS, COMPASS LIMIT DEVICES OR WING OPENING HINDRANCES.



FOR A CORRECT ADJUSTMENT OF THE WINDOW FRAME CLOSING SEE THE INDICATIONS GIVEN IN PAR. 5.6.

5.3- BOTTOM HUNG WINDOWS (Fig. 10 and 26 - 36)

- 1) Open the package (**par. 3.7**) and extract the various components;
- 2) **Fig. 26-** With a pencil draw the centre line "Y" of the window frame;
- 3) **Fig. 27-** Align to the centre line the window frame connection bracket using as reference the centre line indicator (**Ref. 1**) located in the middle of the same, then mark the drilling points on the frame;
- 4) **Fig. 28/29-** With a suitable drill, bore four holes of $\varnothing 3.7$ mm on the frame and tighten the bracket with the suitable screws;
- 5) **Fig. 30-** Align the bottom hung bracket with the centre line of the window using as reference the central hole of the fastening screws and position the bottom hung bracket at **E** (**see Fig. 7b**), then mark the drilling points;
- 6) **Fig. 31/32-** With a suitable drill, bore 3 holes of $\varnothing 3.7$ mm on the wing and tighten the

Fig. 10

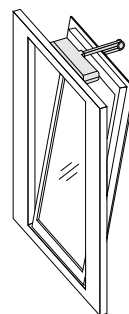

bracket with proper screws;

- 7) **Fig.33-** Tighten with the two standard supplied screws (**Ref. 1**) the actuator on the bracket connecting it to the window frame in the position "0" (**see Fig. 7b**) and unscrew the chain adjustment end screw;
- 8) **Fig. 34-** Select the position of the actuator with reference to the bracket connecting it to the window frame (**see Fig. 7b**) and connect the chain end to the bottom hung bracket;
- 9) **Fig. 35/36-** Adjust the opening stroke by the switch (**Fig. 35 - Ref. 1**) located on the right side of the actuator according to the opening of the wing and tighten the chain end adjustment screw (**Fig. 36 - Ref. 2**);



TO CHANGE THE PRE-SET STROKE, USE A SCREWDRIVER (FIG. 35) WITH SUITABLE TIP. MAKE SURE TO INSERT THE TIP UP TO THE MICROSWITCH BASE AND TO SHIFT IT COMPLETELY. AN INCORRECT IN-BETWEEN POSITION STALLS THE ACTUATOR.

- 10) Perform the electric connections in compliance with the provisions of **par. 5.4** and with reference to the wiring diagram.



THE SELECTION OF THE STROKE MUST BE PERFORMED WITH SWITCHED OFF ACTUATOR EXCLUSIVELY BY COMPETENT AND QUALIFIED TECHNICAL PERSONNEL.



CAUTION: VERIFY THAT THE SELECTED STROKE IS SOME CENTIMETRES LOWER THAN THE STROKE EFFECTIVELY ALLOWED BY MECHANICAL LOCKS, COMPASS LIMIT DEVICES OR WING OPENING HINDRANCES.



FOR A CORRECT ADJUSTMENT OF THE WINDOW FRAME CLOSING SEE THE INDICATIONS GIVEN IN PAR. 5.6.

5.4- ELECTRIC CONNECTIONS (Wiring diagram)



THE ELECTRIC CONNECTION OF THE ACTUATOR CAN BE PERFORMED ONLY BY COMPETENT AND QUALIFIED TECHNICAL PERSONNEL SATISFYING THE TECHNICAL AND PROFESSIONAL REQUIREMENTS FORESEEN BY THE LAW IN FORCE IN THE COUNTRY OF INSTALLATION ISSUING TO THE CUSTOMER A DECLARATION OF CONFORMITY FOR THE CONNECTION AND/OR THE PLANT PERFORMED.



BEFORE PERFORMING THE ELECTRIC CONNECTION OF THE ACTUATOR, VERIFY THE CORRECT INSTALLATION ON THE WINDOW.



THE ELECTRIC CONNECTION OF THE VERSION 24V HAS TO BE CARRIED OUT WITH A VERY LOW SAFETY VOLTAGE FEEDER PROTECTED AGAINST SHORT CIRCUITS.



THE MAINS TO WHICH THE ACTUATOR IS CONNECTED MUST COMPLY WITH THE REQUIREMENTS OF THE LAWS IN FORCE IN THE COUNTRY OF INSTALLATION, AS WELL AS SATISFY THE TECHNICAL FEATURES GIVEN IN TAB. 1 AND ON THE RATING PLATE AND THE "CE" MARKING (PAR. 3.1). THE SECTION OF THE MAINS CABLES MUST BE PROPERLY SIZED ACCORDING TO THE ABSORBED ELECTRIC POWER (SEE RATING PLATE AND "CE" MARKING).



ANY TYPE OF ELECTRIC MATERIAL (PLUG, CABLE, TERMINALS, ETC.) USED FOR THE CONNECTION MUST BE SUITABLE FOR THE USE, WITH "CE" MARKING AND COMPLYING WITH THE REQUIREMENTS FORESEEN BY THE LAWS IN FORCE IN THE COUNTRY OF INSTALLATION.



TO ENSURE A CORRECT SEPARATION FROM THE MAINS, IT IS COMPULSORY TO INSTALL UPSTREAM OF THE DEVICE A BIPOLAR TEMPORARY SWITCH (PUSH-BUTTON) OF APPROVED TYPE. UPSTREAM OF THE CONTROL LINE, IT IS COMPULSORY TO INSTALL AN UNIPOLAR CUTOFF SWITCH WITH CONTACT OPENING OF AT LEAST 3 mm.



BEFORE PERFORMING THE ELECTRIC CONNECTION OF THE ACTUATOR, VERIFY THAT THE POWER SUPPLY CABLE IS NOT DAMAGED. SHOULD IT BE DAMAGED, IT MUST BE REPLACED BY THE MANUFACTURER OR BY THE TECHNICAL ASSISTANCE SERVICE OR IN ANY CASE BY AUTHORIZED OPERATORS.

5.5- CONTROL DEVICES



THE CONTROL DEVICES USED TO DRIVE THE ACTUATOR MUST ENSURE THE SAFETY CONDITIONS FORESEEN BY THE LAWS IN FORCE IN THE COUNTRY OF USE.

According to the different type of installations, the actuators can be driven by the following control devices:

1) MANUAL PUSH-BUTTON:

Bipolar switch button with central OFF position, with biased-off switch;

2) CONTROL AND FEEDING UNIT:

Microprocessor control units controlling the single actuator or more than one actuator simultaneously by means of one or more manual push-buttons, an infrared remote control or a 433 Mhz radio control.

To these control units, it is possible to connect the rain sensors, the wind sensor and the brightness sensor;



THE EVENTUALLY USED UNITS MUST SUPPLY A VOLTAGE FOR MAX. 120 s.

3) SYNCHRONIZATION UNIT:

Microprocessor control unit controlling by means of a manual push-button the simultaneous operation of 2 or 3 actuators installed on a single window assuring the regular opening and closing movement.

5.6- ADJUSTMENT OF THE WINDOW FRAME CLOSING (Fig. 36)

THE CORRECT ADJUSTMENT OF THE WINDOW FRAME CLOSING ENSURES THE LIFE AND THE TIGHTNESS OF THE SEALS, AS WELL AS THE GOOD OPERATION OF THE ACTUATOR.

A good method to perform a correct assembly, consists in verifying that after the disabling of the gear motor the window seals are correctly compressed. Should this not occur, adjust again the chain end by placing it back as needed and eventually by shifting the actuator on the various positions offered by the bracket and then by adjusting the chain end (see Tab. 1).

As shown in Fig. 36, although the window is closed, the chain end adjustment screw (Ref. 2) is located outside the slit (Ref. 1) located on the actuator body causing therefore the failed tripping of the limit switch related to the chain re-entering.

In this case, the actuator motor remains under maximum stress conditions until the electronic protection tripping and the “BUZZER” enabling.
This acoustic warning device emits a continuous “beep” until the actuator is connected to the power supply.



CONSIDERING THAT THIS ADDITIONAL SAFETY DEVICE HAS BEEN DEVELOPED IN ORDER TO OFFER A RAPID SYSTEM TO DETECT ANY EVENTUAL ANOMALY IN THE ASSEMBLY OF THE DEVICE, FOR A CORRECT INSTALLATION OF THE PRODUCT IT IS COMPULSORY TO FOLLOW ALL THE ASSEMBLING PROCEDURES DESCRIBED IN THIS MANUAL.

5.7-EMERGENCY PROCEDURES

Should it be necessary to open the window manually due to power supply failure or mechanism block, follow these instructions:



BEFORE PERFORMING ANY TYPE OF INTERVENTION ON THE ACTUATOR AND ON THE WINDOW, IT IS COMPULSORY TO DISCONNECT THE POWER SUPPLY OF THE ACTUATOR AND TO PUT ON "0" THE EVENTUAL SWITCHES OF THE CONTROL DEVICES.



IT IS COMPULSORY TO PADLOCK THE MAIN SWITCH OF THE DISCONNECTION DEVICE INSTALLED ON THE MAINS IN ORDER TO AVOID ANY UNEXPECTED START. IF THE MAIN SWITCH CANNOT BE PADLOCKED, IT IS COMPULSORY TO PLACE A SIGN FORBIDDING THE ENABLING.



IN SOME CASES, THE EVENT OF POSSIBLE ANOMALIES MIGHT STALL ALSO OTHER ACTUATORS CONNECTED IN PARALLEL. TO FIND THE SUPPOSED MALFUNCTIONING ACTUATOR, RUN SOME CLOSING OPERATIONS IN SUCCESSION (ABOUT 10 OPERATIONS EVERY 2 SECONDS), TILL THE WORKING ACTUATORS START RUNNING AGAIN.

- **Top hung opening: Fig. 11-** Insert a screw driver in the right side opening (Ref. 1) of the quick coupling and lever on the reed holding the chain end and extract the actuator.
- **Bottom hung opening: Fig. 12-** Act on the chain end adjustment screw (Ref.1) and let the actuator rotate upwards until the same is removed from the bottom hung opening bracket.

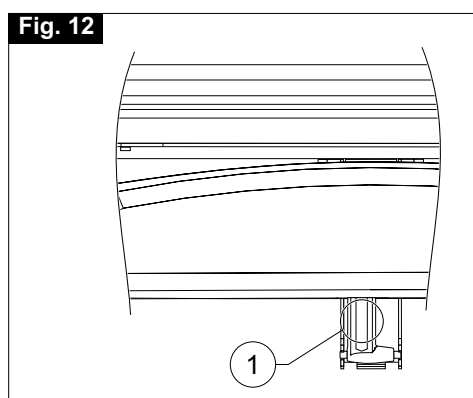
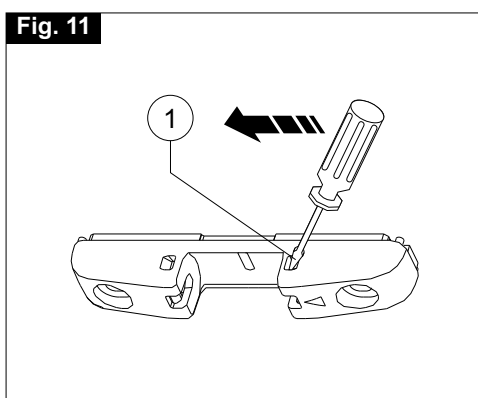

6.1- USE OF THE ACTUATOR



THE ACTUATOR CAN BE USED ONLY BY A USER ACTING IN COMPLIANCE WITH THE INSTRUCTIONS GIVEN IN THIS MANUAL AND/OR IN THE MANUAL OF THE ACTUATOR COMMAND DEVICE (e.g.: WIND AND RAIN CONTROL UNIT).



BEFORE USING THE ACTUATOR, IT IS COMPULSORY FOR THE USER TO READ AND UNDERSTAND IN ALL ITS PARTS THIS MANUAL, AS WELL AS THE EVENTUAL MANUAL OF THE INSTALLED CONTROL DEVICE TYPE.



BEFORE OPERATING THE ACTUATOR, THE USER MUST COMPULSORILY VERIFY THAT NEAR AND/OR UNDER THE WINDOW THERE ARE NOT ANY PERSON, ANIMAL AND THING WHOSE SAFETY MAY BE ACCIDENTALLY JEOPARDISED (SEE PAR. 4.4).



DURING THE OPERATION OF THE ACTUATOR CONTROL DEVICE, THE USER HAS TO COMPULSORILY OCCUPY A CONTROL POSITION ENSURING VISUAL CONTROL ON THE WINDOW MOVEMENT.



THE FUNCTION EFFICIENCY AND THE RATED PERFORMANCE OF THE ACTUATOR, OF THE WINDOW FRAME ON WHICH IT IS INSTALLED AND OF THE ELECTRIC EQUIPMENT MUST BE VERIFIED STEADILY IN TIME BY PERFORMING, WHEN NECESSARY, INTERVENTIONS OF ROUTINE AND SUPPLEMENTARY MAINTENANCE ASSURING THE OPERATION CONDITIONS IN COMPLIANCE WITH THE SAFETY REGULATIONS.



ALL ABOVE MENTIONED MAINTENANCE INTERVENTIONS MAY BE PERFORMED EXCLUSIVELY BY TECHNICAL COMPETENT AND QUALIFIED TECHNICAL PERSONNEL SATISFYING THE TECHNICAL AND PROFESSIONAL REQUIREMENTS FORESEEN BY THE LAW IN FORCE IN THE COUNTRY OF INSTALLATION.

The use of the actuator allows automatic control of the opening and closing of the window according to the type of control device installed (see par. 5.5).

7.1- GENERAL INSTRUCTIONS



IF THE ACTUATOR WORKS INCORRECTLY, CONTACT THE MANUFACTURER.



ANY WORK ON THE ACTUATOR (E.G.: POWER CABLE, ETC.) OR ITS COMPONENTS MAY ONLY BE CARRIED OUT BY PERSONNEL QUALIFIED BY THE MANUFACTURER. MANUFACTURER DECLINES ALL LIABILITY FOR WORK PERFORMED BY UNAUTHORISED PEOPLE.

The actuator incorporates components that do not require significant routine or extraordinary maintenance operations.

In heavy-duty conditions (e.g.: very dirty work areas, frequent use, elevated temperature changes, load variations caused by wind or snow, etc.) make sure, at least once every 6 months, that the actuator assembly components are clean, the fixing systems (brackets and screws) are tight, the window frame is not deformed and the seals are tight, and check the cables and connectors.

If any malfunctions arise after cleaning or inspection, contact the technical assistance

8- DEMOLITION

ΣOL N

8.1- GENERAL INSTRUCTIONS



THE DEMOLITION OF THE ACTUATOR MUST OCCUR IN COMPLIANCE WITH THE LAWS IN FORCE ON ENVIRONMENT PROTECTION.



DIFFERENTIATE THE PARTS MAKING UP THE ACTUATOR ACCORDING TO THEIR DIFFERENT MATERIAL TYPE (PLASTIC, ALUMINIUM, ETC.).

9- SPARE PARTS AND ACCESSORIES UPON REQUEST

ΣOL N

9.1- GENERAL INSTRUCTIONS



THE USE OF "NON-ORIGINAL" SPARE PARTS AND ACCESSORIES WHICH MAY ENDANGER THE SAFETY AND THE EFFICIENCY OF THE ACTUATOR IS FORBIDDEN. THIS ACTION SHALL INVOLVE THE WARRANTY EXPIRATION.



ORIGINAL SPARE PARTS AND ACCESSORIES HAVE TO BE REQUESTED EXCLUSIVELY TO YOUR DEALER OR TO THE MANUFACTURER STATING TYPE, MODEL, SERIAL NUMBER, AND YEAR OF CONSTRUCTION OF THE ACTUATOR.

Fig. 13

DOME ASSEMBLY BRACKET

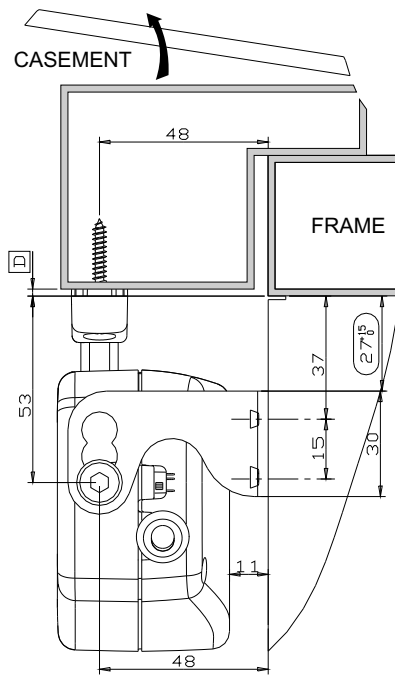

FOR A CORRECT OPERATION OF THE ACTUATOR, "D" MUST HAVE A VALUE INCLUDED BETWEEN 0 mm AND 30 mm.

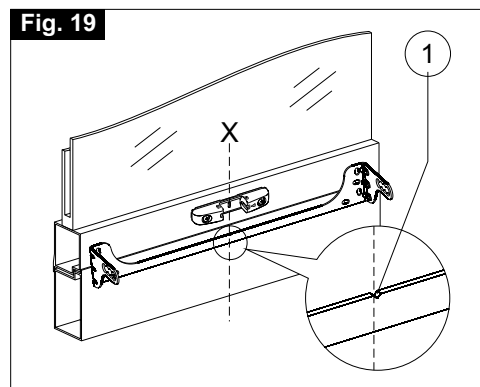
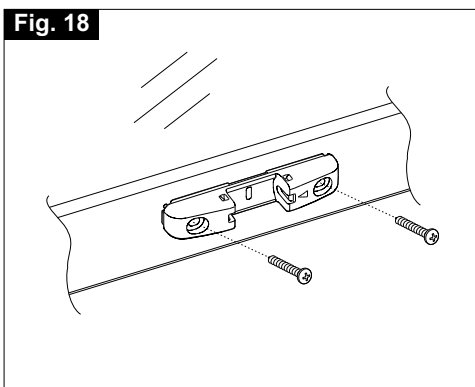
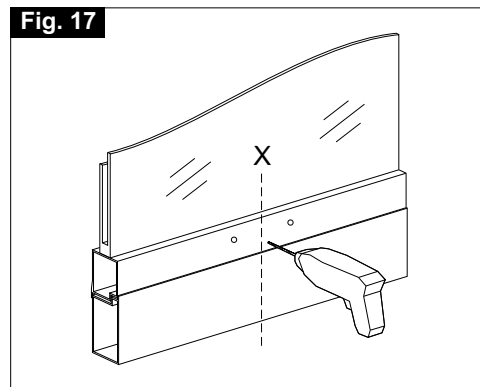
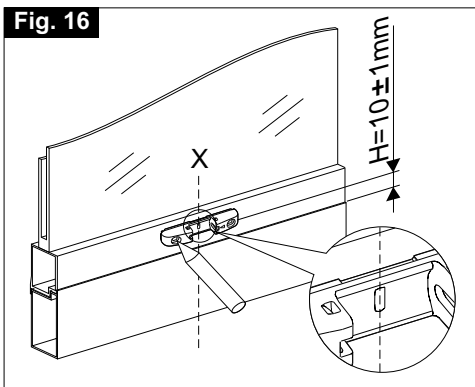
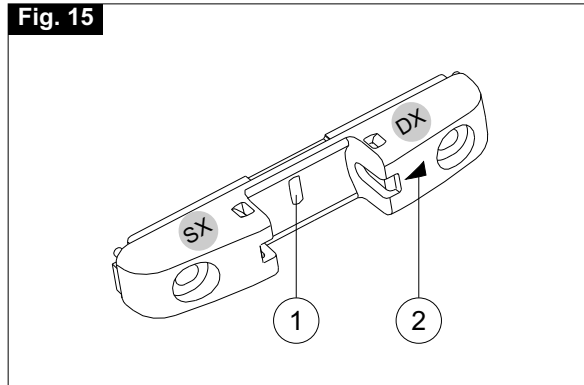
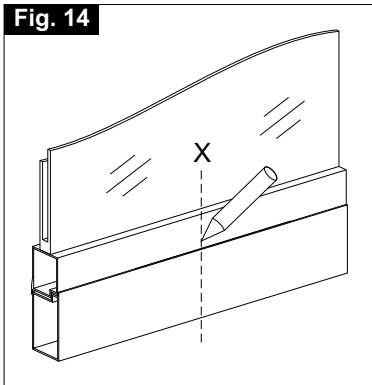

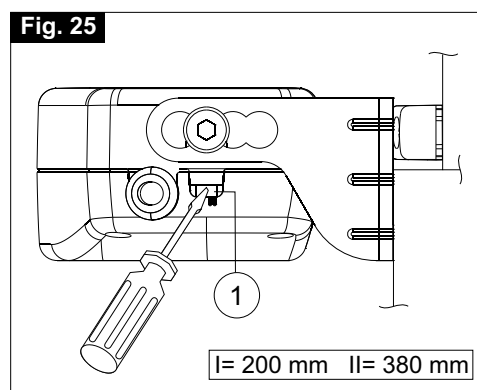
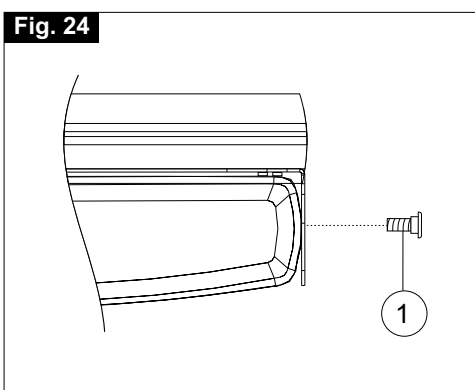
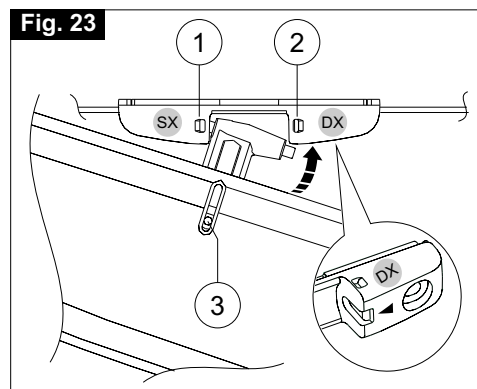
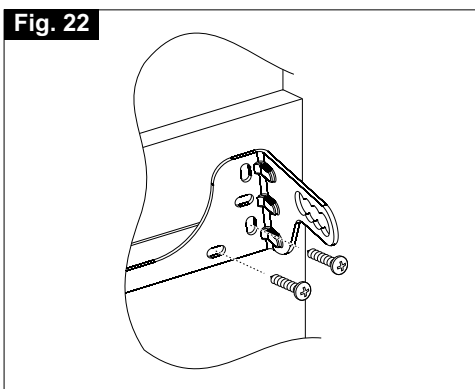
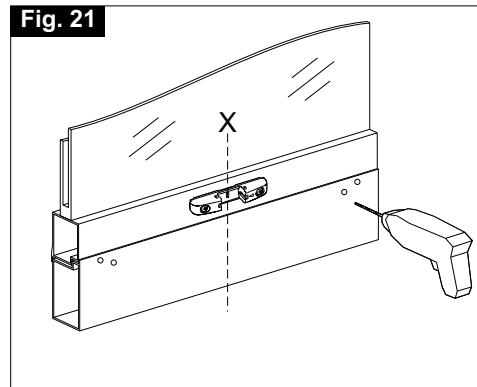
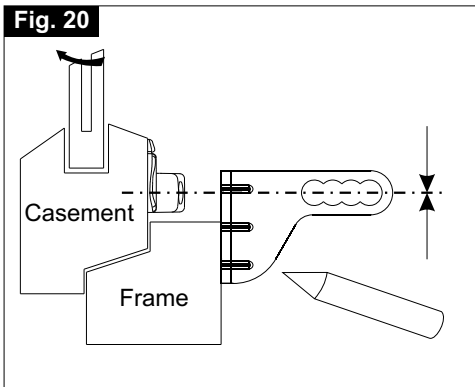

Fig. 26

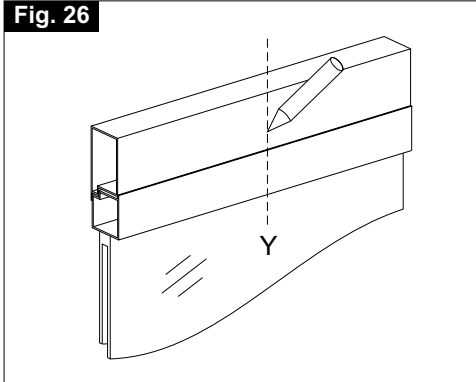

Fig. 27

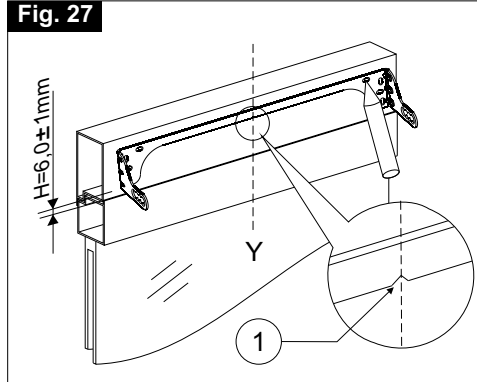

Fig. 28

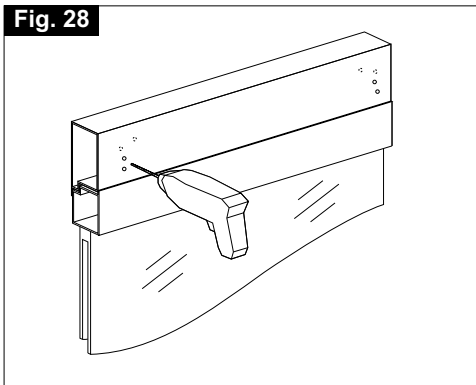

Fig. 29

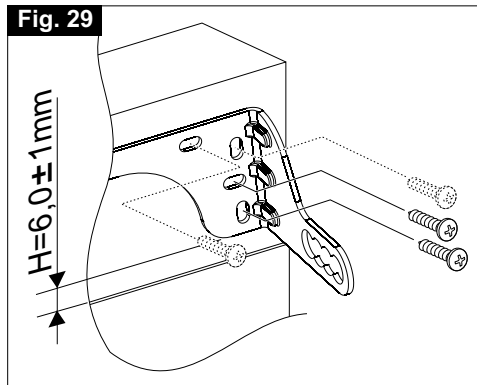

Fig. 30

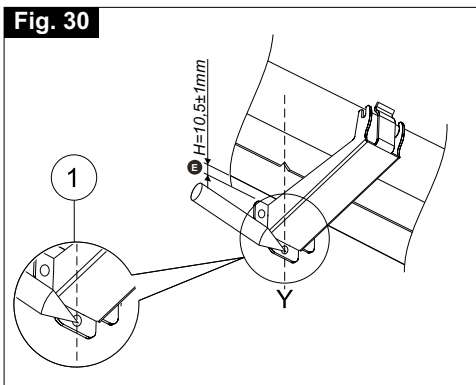
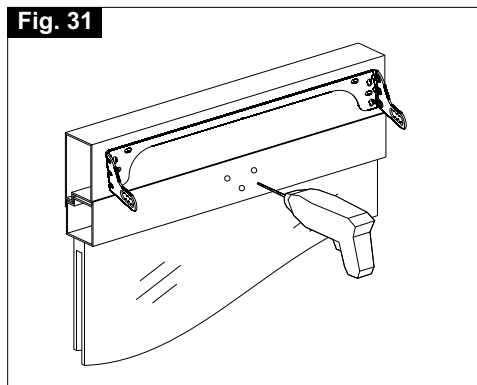
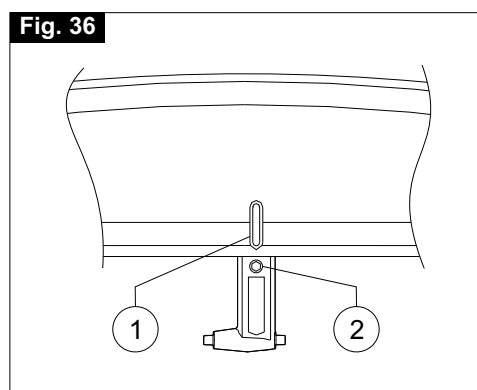
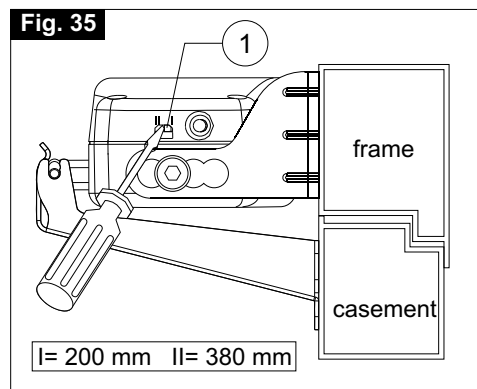
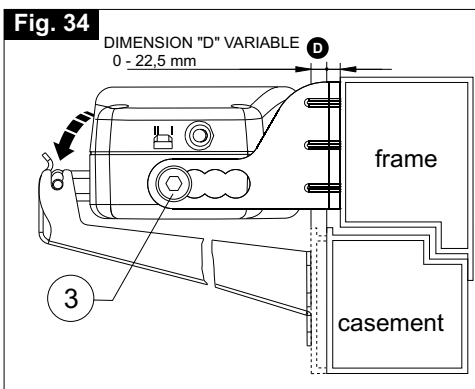
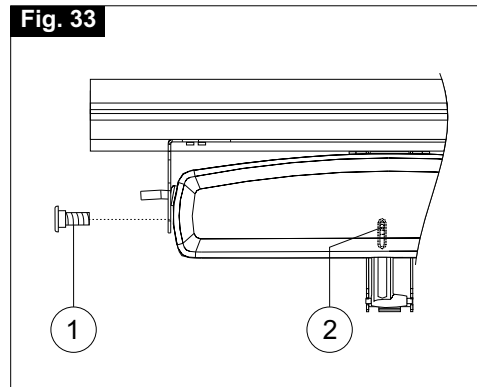
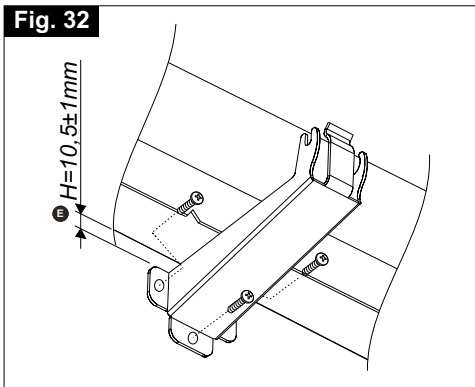
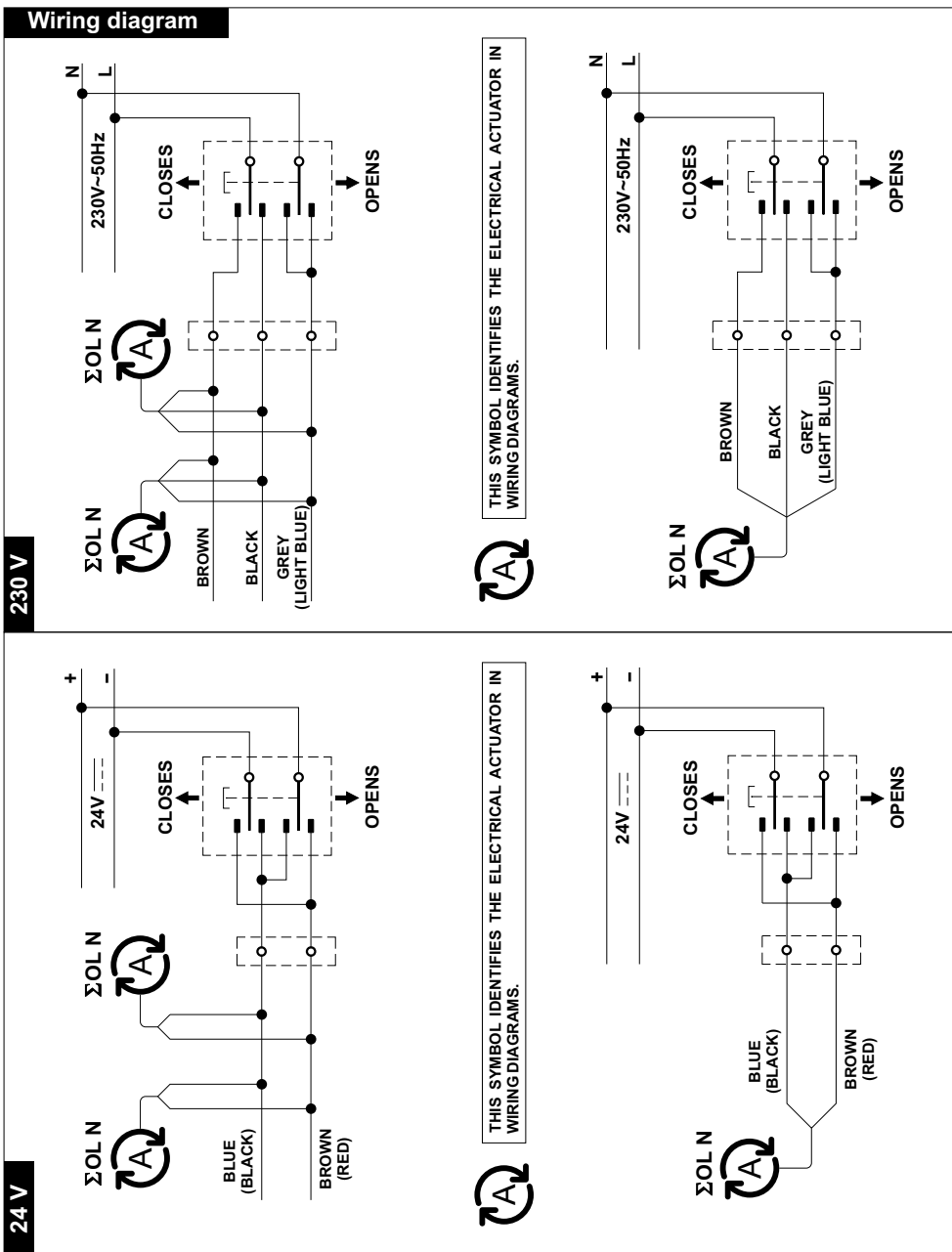

Fig. 31







ΣΟΛ Ν